

# T-7211

## 2" Mini DA Sander

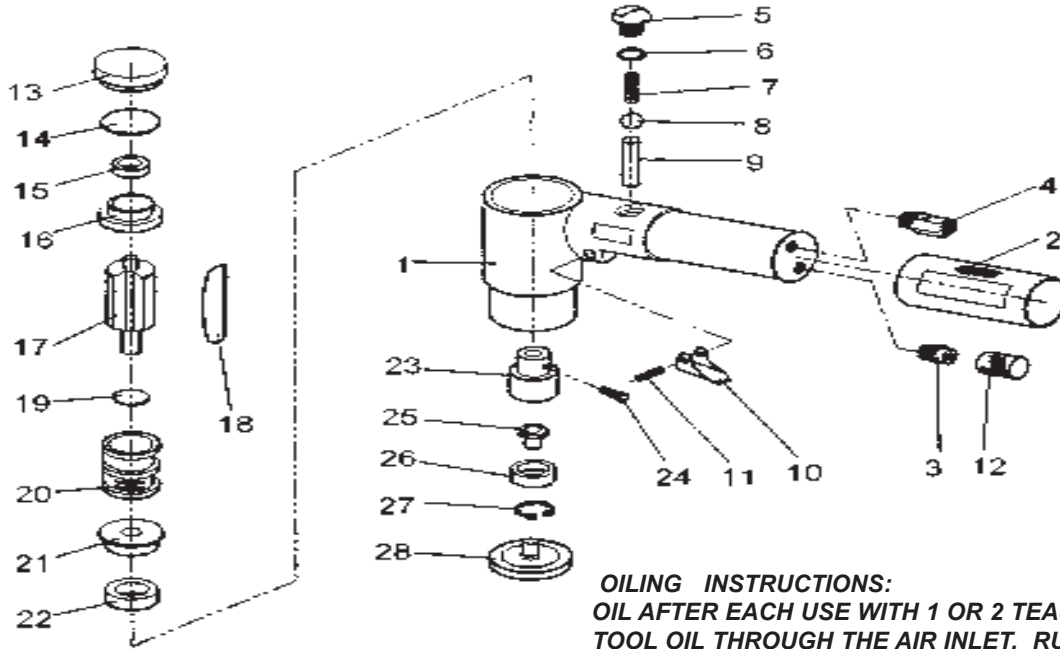

**OILING INSTRUCTIONS:**  
**OIL AFTER EACH USE WITH 1 OR 2 TEASPOONS OF AIR-TOOL OIL THROUGH THE AIR INLET. RUN FOR ONE SECOND TO COAT ALL INTERNAL PARTS.**

### USE 90 PSI MAXIMUM

Ref.#	Part #	Description	Qty.
1	721101	Body	1
2	721102	Rubber Sleeve	1
3	721103	Muffler Mount	1
4	721104	Regulator Assembly	1
5	721105	Plug	1
6	721106	"O" Ring	1
7	721107	Spring	1
8	721108	Steel Ball	1
9	721109	Valve Pin	1
10	721110	Lever	1
11	721111	Spring Pin	1
12	721112	Exhaust Assembly	1
13	721113	Cap	1
14	721114	"O" Ring	1

Ref.#	Part #	Description	Qty.
15	721115	Bearing	1
16	721116	Rear End Plate	1
17	721117	Rotor	1
18	721118	Rotor Blade (5 per set)	1 set
19	721119	Collar	1
20	721120	Cylinder	1
21	721121	Front End Plate	1
22	721122	Bearing	1
23	721123	Spindle	1
24	721124	Screw	1
25	721125	Driver Spindle	1
26	721126	Bearing	1
27	721127	Retaining Ring	1
28	721128	Disk Pad (PSA)	1

505 N. Railroad Ave.  
P.O. Box 1117  
Boynton Beach, Florida 33435

**SEE OUR CATALOG**  
at  
[www.taylorpneumatic.com](http://www.taylorpneumatic.com)

PH. 561-732-1111  
FAX 561-731-4412  
Toll Free 800-805-8665

09/07 TPTCDPT  
all rights reserved  
COPYRIGHT 2007  
final